

# AU2700 QC Receiver Interface (v 3.0.0)

## 1. Introduction

### 1.1. Intended use

QCAU2700A is a QC receiver interface intended to

- Receive analytical data from an Olympus AU2700 clinical chemistry analyser through a serial port.
- Retrieve QC data, repeatability data, calibration flags and changes of reagent lot.
- Re-send this data to MultiQC, a QC management software that can be downloaded at [www.multiqc.com](http://www.multiqc.com).

QCAU2700B is to be used when the same QC computer must receive QC data simultaneously from two Olympus AU2700 analysers (see section 4.1).

QCAU2700A and B, version 3.0.0, are compatible with Windows 2000 to Windows 7.

### 1.2. Starting and stopping QCAU2700

The receiver interface is not directly launched or closed in routine use. It is under control of MultiQC. The interface is automatically launched or closed when MultiQC is launched or closed. Any action that would close a normal program (clicking the Windows close box or pressing the keys Alt+F4) only iconizes the QC receiver interface.

After launching MultiQC, you can check that the interface QCAU2700 is running:

1- Its icon is shown in the Windows taskbar.



2- A new sub-menu is added to the main menu of MultiQC **Direct connections**.

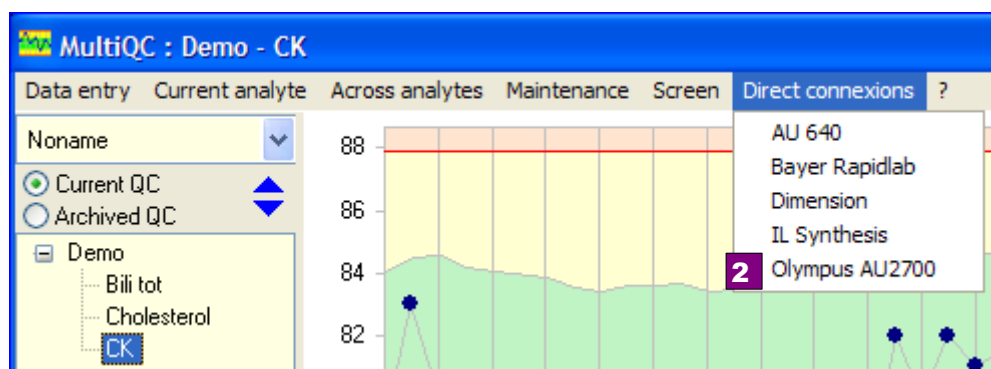

### 1.3. Data management

#### ➤ QC assays

QC assays can be extracted from the output stream of analytical results by two means:

- Keeping the built-in QC system of the AU2700, control materials are identified by their position on a green rack (the racks devoted to QC samples). Concentrations are exported in a specific format that the receiver interface can recognize.
- Dropping out the built-in QC system of the AU2700, control materials can be also assayed as normal patient samples but identified by a reserved identifier (for instance QC1, QC2 and QC3 for a 3-level QC).

Olympus analysers do not export dates and times of tests. QC results are therefore dated with the time when they are retrieved by the QC receiver interface. The error is quite negligible because QC data are collected in real time.

➤ **Repeatability assays**

The receiver interface recognises repeatability assays thanks to a reserved identifier (**rep** by default). To perform repeatability verification, the lab assistant has only to make 10, 20 or 30 repeated assays of the same sample identifying every one by **rep**.

➤ **Reagent blank and calibration assays**

A specific output message is sent by the AU2700 analyser and is recognised by the receiver interface.

➤ **Changes of reagent lots**

Olympus analysers can transmit the reagent lot and bottle number that were used for every assay. Ask your Olympus representative for the password necessary to access the set-up screen of the analyser in order to check the box “*Reagent inf. exists online*”.

Thus the QC interface will be able to re-send to MultiQC the reagent lots and bottle numbers and MultiQC will automatically display a small icon in its events bar whenever a new lot/bottle of reagent 1 appears. This greatly facilitates the interpretation of QC charts.

## 2. Running the interface

In routine work, the QC receiver interface stays ionised in the Windows taskbar. QCAU2700 has to be restored only on installation to enter communication and analytical parameters.

### 2.1. Tab “From analyser”

This panel shows the raw messages received from the analyser. Only the 200 latest lines are kept.

1- The button **Clear** erases all the lines.

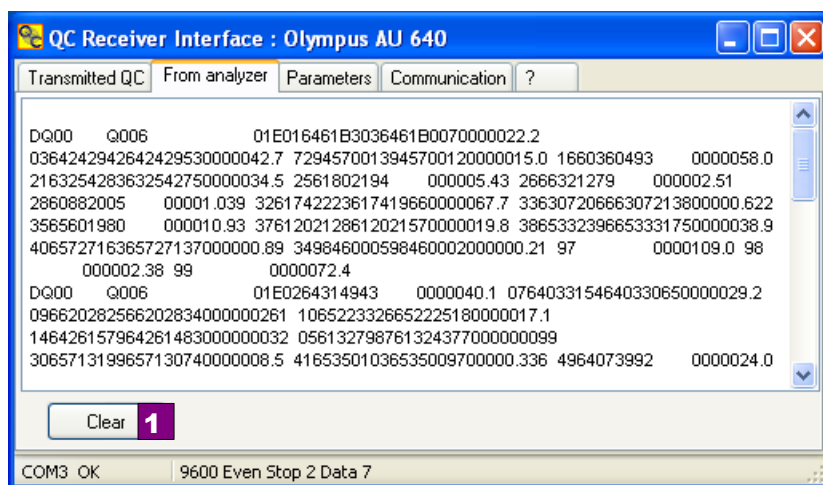

### 2.2. Tab “Transmitted QC”

This panel shows the latest 200 QC results sent to MultiQC.

↔ Width of columns can be adjusted.

1- The button **Clear** erases all the lines in the list view.

2- The column **Level** displays a level number (for a QC result) or a label -**Blk**, **Cal**, **Rpt** - respectively for blank, calibration,

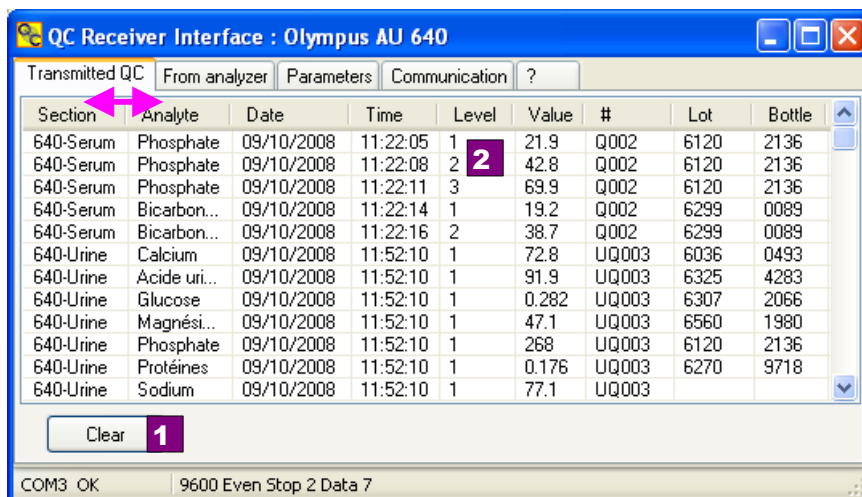

and repeatability).

### 2.3. Tab “Parameters”

Here you can edit the “ini” file that saves the working parameters of the interface. This file is made of six sections (between brackets).

#### ➤ [Olympus]

These parameters must be the same as the Olympus ones. You must only edit the right part of each line, after the sign =

Select the menu of the analyser <Parameters → Format → Requisition format> and copy the following fields to the receiver interface :

- Sample ID
- Sex : Type <Yes> if the box is checked on the Olympus screen.
- Age : Type <Yes> if the box is checked on the Olympus screen.
- Patient information : Enter the total number of digits by adding the lengths of the 6 attributes available on the Olympus analyser.

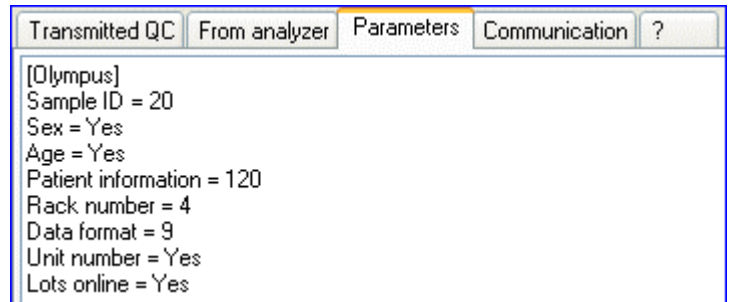

Select the menu of the analyser <Parameters → Online → Setup tab> and select **Real time** in the 10 drop down pick lists under the sub-title **Result transfer** (from **Routine normal** to **Reagent blank**).

Select the menu of the analyser <Parameters → Online → Protocol tab> and copy the following fields to the receiver interface :

- Rack number : Set this number to 4, 5 or 0, matching the “4”, “5” or “No” of the field “Rack No” of the analyser.
- Data format : Set this format to 6 or 9, matching the same field of the analyser.
- Unit number : Yes if checked on the Olympus screen.
- Lots online : Type <Yes> if the box “Reagent inf. exists online” is checked in the set-up of the Olympus analyser. This set-up is password protected and you might need the help of an Olympus representative to access it. Checking the box “Reagent inf exists online” changes the format of the output signal of the analyser because this adds reagent lots and bottles to the information transmitted. The set-up of the LIS must therefore be adapted to the new format.

#### ➤ [MultiQC]

You must only edit the right part of the =

- Interface name is the name that is shown in the Windows taskbar and in the additional sub-menu that is created in MultiQC. Change the interface name if you have two same analysers in order to be able to recognise each one.
- Repeatability : Enter the default identifier thanks to which the receiver interface will be able to recognise the repeatability assays.

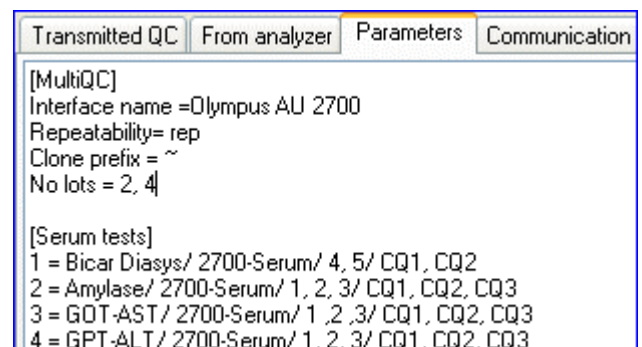

- Clone prefix : Refer to the user manual of MultiQC for an explanation of the **cloned analytes**. They are used to temporarily store assays of a new batch of control material (phase I) while keeping on controlling analytical methods with an older batch which is about to be exhausted. Cloned (=duplicated) analytes are always prefixed in MultiQC by a “tilde”, for instance **~glucose**. You may perform assays of the new batch in a green rack and redirect results to **~Analytes** proceeding as shown in section 14-3 of the user manual of MultiQC. An alternative way is to perform assays in a red rack as patient samples. The identifiers reserved for QC (see section 1.3 above) must be prefixed by the **clone prefix**. It may be a tilde ((for instance **~QC1**, **~QC2**, **~QC3**), or any other letter (&, \$, % ...) if the key ~ is not available on the keyboard. In any case, the clone prefix of the AU interface will be turned into a tilde ~ in MultiQC.
- No lots : MultiQC processes reagent lots and bottle numbers. When these data are transmitted, the status and reagent bars are automatically updated every time a new lot or bottle of reagent 1 is started. Sometimes you may wish to stop this automatic update. Type in the relevant list of test numbers after **<No lots >**. In the picture above, the automatic update of bottles is locked for tests 2 and 4 (Amylase and ALT).

➤ **[Serum tests], [Urine tests], [Other tests]**

Each line is made of four items of information

- Numbers before ‘=’ are the online numbers of tests in the AU analyser. It is practical but not mandatory to sort the lines by increasing online numbers.
- The first word after ‘=’ is the name of each test in MultiQC.
- The following word after the first ‘/’ is the name of the section of the analytes tree view that will contain the test.

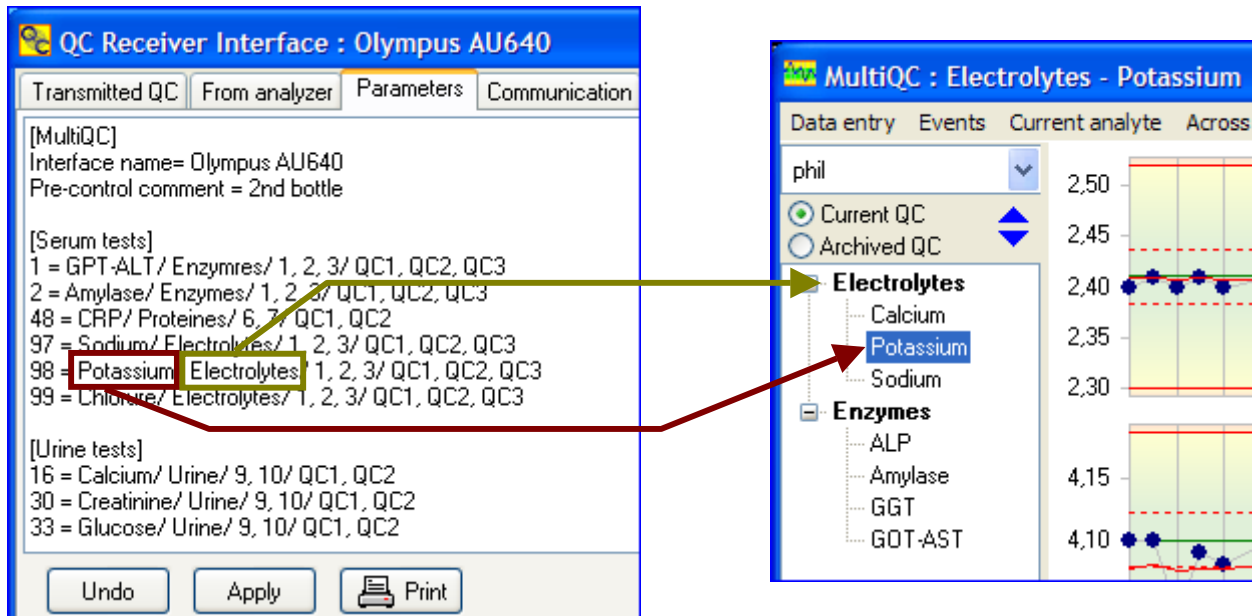

- Optional series of numbers after the second ‘/’ are the positions of QC materials in the green racks of the AU analyser. The first one will become level 1 in MultiQC and so on.

Green rack number	Positions in the “ini” file
1	1, 2, ..., 10
2	11, 12, ..., 20
3	21, 22, ..., 30
4	31, 32, ..., 40

- Optional series of identifiers after the third ‘/’ are the identifiers which must be assigned to QC materials when they are assayed in patient mode (not case sensitive). The first one will become level 1 in MultiQC and so on. QC. Identifiers are not necessary if control materials are always passed in QC mode (green rack).

**Example1** : 16 = Lipase/ Enzyme/ 8, 9, 10

- Test 16 of the AU2700 analyzer will be named “Lipase” in MultiQC and Lipase will belong to the group “Enzyme”
- Lipase concentrations of the control materials placed in position 8, 9 and 10 of the green rack number 1 will be plotted in charts 1, 2 and 3 of MultiQC.

**Example 2** : 45 = CRP/ Proteins/ 15, 16 / QC1, QC2

- Test 45 of the AU2700 analyzer will be named “CRP” in MultiQC and CRP will belong to the group “Proteins”
- CRP concentrations of the control materials placed in position 5 and 6 of the green rack number 2 will be plotted in charts 1 and 2 of MultiQC.
- CRP concentrations of patient samples identified by “QC1” and “QC2” will be also plotted in charts 1 and 2 of MultiQC.

#### ➤ [Inner and outer]

AU2700 analysers have two reaction trays : the inner one and the outer one. They are independently calibrated and QCed. A given test may be set up to be performed only in the inner tray, only in the outer tray or randomly in both trays (to increase the analytical throughput). In the latter case, QC is duplicated for each control level leading to an inner result and an outer result.

The inner QC result and the outer QC result are not independent as if the two assays were performed on two separate analysers. Results must be managed from a multivariate point of view. They are therefore associated in the same QC vector in the following order :

Charts of MultiQC	Interleaved levels
1	Level 1 - Inner
2	Level 1 - Outer
3	Level 2 - Inner
4	Level 2 - Outer
5	Level 3 - Inner
6	Level 3 - Outer

- Tests: list of online numbers of tests that are performed in both inner and outer trays. Passing QC samples in the green rack is mandatory for these tests. It is the only way to force the analyser to perform a duplicated control. Never pass QC samples for such test as patient samples.

Do not forget to click the button [Apply](#) after updating parameters.

You can print parameters with the button [Print](#).

## 2.4. Tab “Communication”

Enter the communication parameters of the serial port connected to the analyser. They can be read from the menu of the Olympus analyser : [Parameters](#) → [Online](#) → [Protocol](#) :

- 1- Do not forget to click on the button **Apply** after updating parameters.
- 2- Look at the status bar to check if the serial connection is OK.

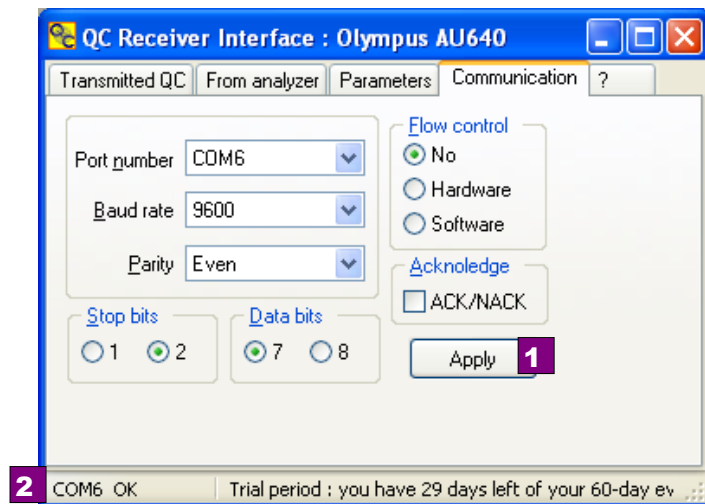

### 3. Data processing by MultiQC

#### 3.1. Reception of data by MultiQC

Received QC and repeatability data are piled up by MultiQC in pending queues while waiting for being reviewed. Blinking warnings are triggered :

- The icon of the interface program blinks blue/orange in the Windows taskbar (only Windows XP).
- A “QC” panel and a “Repeatability” panel blink red/yellow at the left-bottom corner of the main window as soon as data is available.

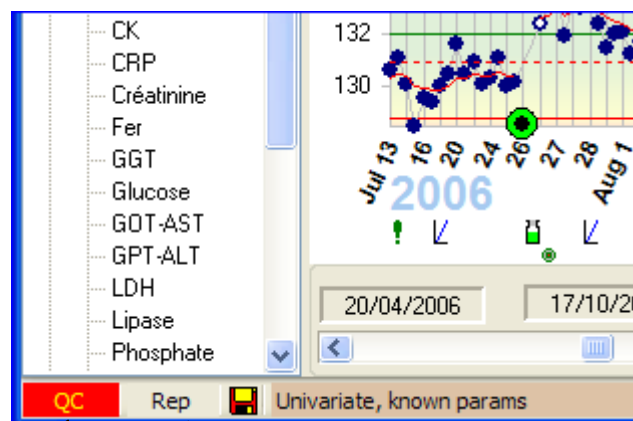

QC data waiting for validation

Repeatability data waiting for review

Reagent blanks and calibrations are directly inserted to the list of events of the relevant analyte. As long as an analyte is “busy”, inserting new events is delayed.

#### 3.2. Assembling QC vectors

In multi-level QC, materials are sequentially assayed by the analyser. For each analyte it is necessary to lump together the different QC levels in a unique vector. This is made on a time interval basis. QC levels are associated in the same QC vector if the time interval between the assays is less that the limit entered in MultiQC :

- Menu : Maintenance→Configuration
- Tab : General
- Field : Max time interval between levels (default 5 minutes)

When rebuilding a QC vector with separate QC values, the final time is the time of the earliest QC value.

Do not start validation before all the QC levels have been received

### 3.3. Validating QC data

Click the yellow/red blinking panel “QC” and proceed as indicated in the user manual of MultiQC.

If the name of an analyte is unknown by MultiQC, a new analyte is automatically created with default parameters. Later, you will have to enter the appropriate parameters through the main menu [Maintenance](#)→[Analytes](#).

### 3.4. Reviewing repeatability data

Click the yellow/red blinking panel “Rep” and proceed as indicated in the user manual of MultiQC.

## 4. Installation

### 4.1. Installation of interfaces

Download MultiQC at [www.multiqc.com](http://www.multiqc.com) and install the package. The version of MultiQC must be 6.1.0.0 or later (the number of version is visible in the “About” box : main menu <? → [About](#)>).

Download the QCAU2700A receiver interface at [www.multiqc.com](http://www.multiqc.com) and install the package. To comply with the User Access Control of Windows 7, the program files are installed in the folder :

*C:\Program files\MultiQC6\AU640A*

and the data files are installed in a different folder that depends on the version of Windows :

Win XP = *C:\Documents and Settings\All Users\Application Data\MultiQC6\AU2700A*

Vista or Win 7 = *C:\ProgramData\MultiQC6\AU2700A*

By default, Windows hides the folders [C:\Documents and Settings\All Users\Application Data\](#) and [C:\ProgramData](#). To display these folders in the Windows Explorer, you must check the box < *Tool menu -> Folder options -> View tab -> Show hidden files and folders*>.

If you want to connect a second AU2700 analyser to the same QC computer you must download a second interface named QCAU2700B at [www.multiqc.com](http://www.multiqc.com) and proceed likewise. The interfaces AU2700A and AU2700B are identical except the GUIDs (global unique identifiers) which allows MultiQC to recognize each one.

### 4.2. Transferring MultiQC and its AU640A interface to another computer

- Install MultiQC and its interface on the new computer. Two files must be manually copied from the data folder of the source computer to the data folder of the destination computer :
- QCAU2700A.ini : the content of the tab <Parameters>.
- QCAU2700A.dat : the content of the tab <Communication>.

Thus the interface will immediately be ready to work without having to re-enter analytes or communication parameters.

### 4.3. Connecting analyser and computer

#### ➤ AU2700 analyser

AU analysers have only one output socket. This unique serial port is generally taken by the LIS. It is therefore necessary to make use of a unidirectional “spy” connection to retrieve QC data.

In the main screen of the AU analyser, go to the menu **Parameter --> On-line** and select the option **Real time** in the three combo-boxes **QC, Calibration** and **Reagent blank..**

➤ **QC receiver interface**

Edit the communications parameters in the **Communication** panel of the QC receiver interface so that they match the parameters of the analyser

➤ **Connection cable**

Because the output socket of the analyser is taken by a connexion to the LIS, 2 additional wires must be soldered on the DB9 female connector of the LIS cable, plugged into the DB9 male connector of the analyser.

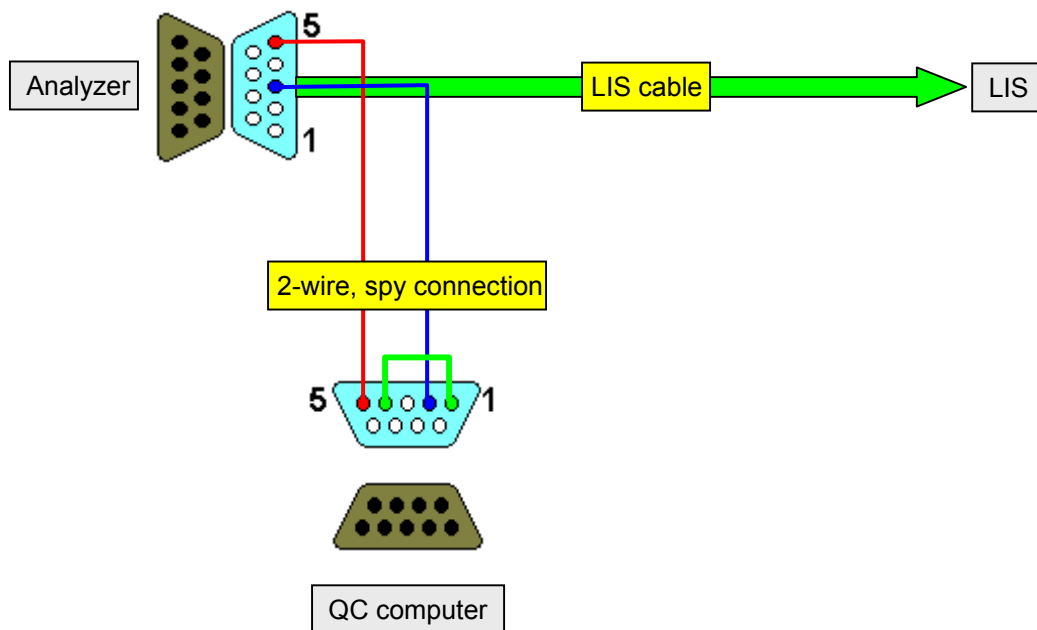

It might be more practical to build a short extension cord (female DB9 / male DB9) with the 2-wire derivation soldered on the female DB9 connector. Thus the derivation can be easily inserted in or removed from the original LIS cable which does not need to be modified.

